

Service Manual, in many cases in actual use. Refer to the Special Service Tool Catalog for a description and ordering instructions for these tools.

OUTBOARD MOTOR NOMENCLATURE

Sometimes the words "right" and "left" are very confusing when referring to the sides of an outboard motor. Therefore, the sides are referred to as STARBOARD or PORT sides. STARBOARD means on the right hand while facing the bow (FRONT) of the boat; PORT means left hand. See Figures 1-1 and 1-2.

Service required for the motor is generally one of three kinds

1. NORMAL CARE AND MAINTENANCE, which includes putting a new motor into operation, storing motors, lubrication, and care under special operating conditions such as salt water and cold weather.
2. OPERATING MALFUNCTIONS due to improper motor mounting, propeller condition or size, boat condition, or the malfunction of some part of the motor. This includes motor tune-up procedures to keep the motor in prime operating condition.
3. COMPLETE DISASSEMBLY and overhaul, such as inspecting a motor that has been submerged or rebuilding trade-in units.

It is important to you as the service man to determine before disassembly just what the trouble is, and how to correct it quickly and with minimum expense to the owner. This section of the manual is designed to help you diagnose motor malfunctions and correct them.

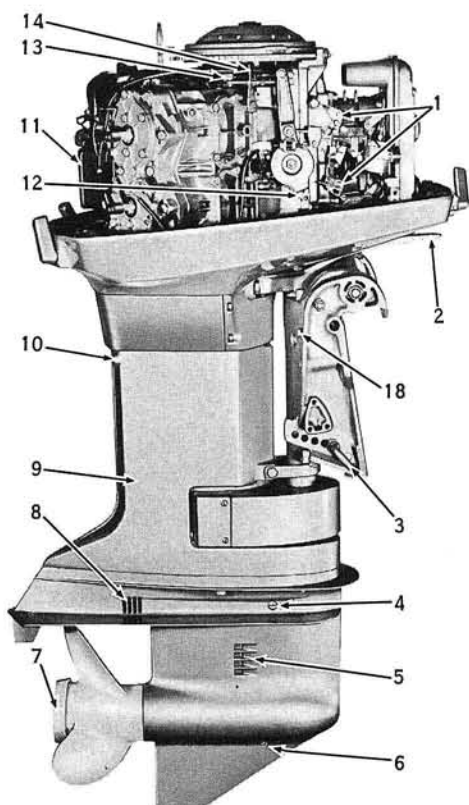

22405

Figure 1-1. Starboard View Less M/C

1. Carburetors
2. Steering bracket
3. Tilt adjustment rod
4. Oil level plug
5. Water intake
6. Oil drain and fill plug
7. Exhaust outlet
8. Water outlet
9. Exhaust housing
10. Exhaust relief
11. Pulse pack
12. Throttle lever
13. Distributor
14. Alternator
15. Lift bracket
16. Fuel pump and filter
17. Exhaust covers
18. Tilt lock lever
19. Water outlet
20. Trim tab
21. Propeller
22. Skeg
23. Gearcase
24. Water intake
25. Stern bracket
26. Air silencer
27. Electric starter
28. 20 amp fuse

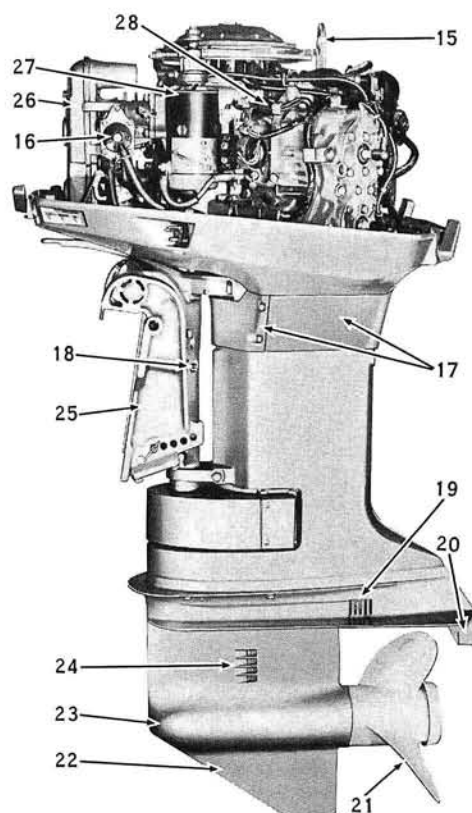

22404

Figure 1-2. Port Side View Less M/C